

# AM.3.VM... / AM.3.VI... MODULAR MAX. PRESSURE VALVES CETOP 3



AM.3.VM / AM.3.VI...

CMP.10... CH. VII PAGE 30  
SCREWS AND STUDS CH. IV PAGE 21

AM.3.VM type pressure regulating valves are available with a pressure range of 2 ÷ 320 bar.

Adjustment is by means of a grub screw or a plastic knob.

Three basic versions are available:  
 - AM3VM on single A or B lines, and on A and B lines, with drainage to T;  
 - AM3VMP on single P line, with drainage to T;  
 - AM3VI on single A or B lines, and on A and B lines, with crossed drainage on A or B (see hydraulic symbols).  
 All versions can accept three types of springs with calibrated ranges as shown in the specifications.

Max. operating pressure	320 bar
Setting ranges:	spring 1 max. 50 bar spring 2 max. 150 bar spring 3 max. 320 bar
Max. flow	40 l/min
Hydraulic fluids	Mineral oils DIN 51524
Fluid viscosity	10 ÷ 500 mm <sup>2</sup> /s
Fluid temperature	-25°C ÷ 75°C
Ambient temperature	-25°C ÷ 60°C
Max. contamination level	class 10 in accordance with NAS 1638 with filter $\beta_{25} \geq 75$
Weight AM.3.VM.A/B/P...	1,2 Kg
Weight AM.3.VM.AB...	1,3 Kg
Weight AM.3.VI.A/B...	2 Kg
Weight AM.3.VI.AB...	2,2 Kg

The cartridge, which is the same for all versions, is the direct acting type CMP10.

**For the minimum permissible setting pressure depending on the spring, see minimum pressure setting curve.**

## ORDERING CODE

<b>AM</b>	Modular valve
<b>3</b>	CETOP 3/NG6
<b>**</b>	<b>VM</b> = Maximum pressure <b>VI</b> = Maximum pressure crossline
<b>**</b>	Adjustment on the lines AM.3.VM Version = <b>A / B / P / AB</b> AM.3.VI Version = <b>A / B / AB</b>
<b>*</b>	Type of adjustment <b>M</b> = Plastic knob <b>C</b> = Grub screw
<b>*</b>	Setting ranges at port A/B/P <b>1</b> = max. 50 bar ( <b>white spring</b> ) <b>2</b> = max. 150 bar ( <b>yellow spring</b> ) <b>3</b> = max. 320 bar ( <b>green spring</b> )
<b>*</b>	Setting ranges at port B (Omit if the setting is same as that at port A) <b>1</b> = max. 50 bar ( <b>white spring</b> ) <b>2</b> = max. 150 bar ( <b>yellow spring</b> ) <b>3</b> = max. 320 bar ( <b>green spring</b> )
<b>**</b>	<b>00</b> = No variant <b>V1</b> = Viton
<b>3</b>	Serial No.

## PRESSURE - FLOW RATE

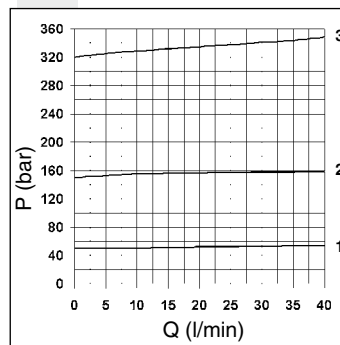

Curves n° 1 - 2 - 3 = setting ranges

## MINIMUM SETTING PRESSURE

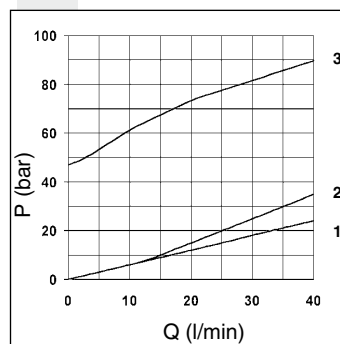

## HYDRAULIC SYMBOLS

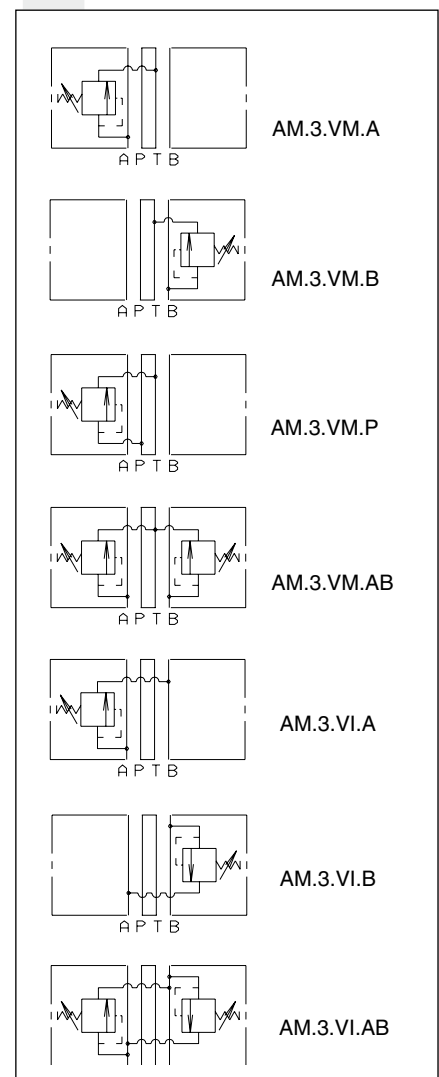

OVERALL DIMENSIONS

4

AM.3.VM.AB...

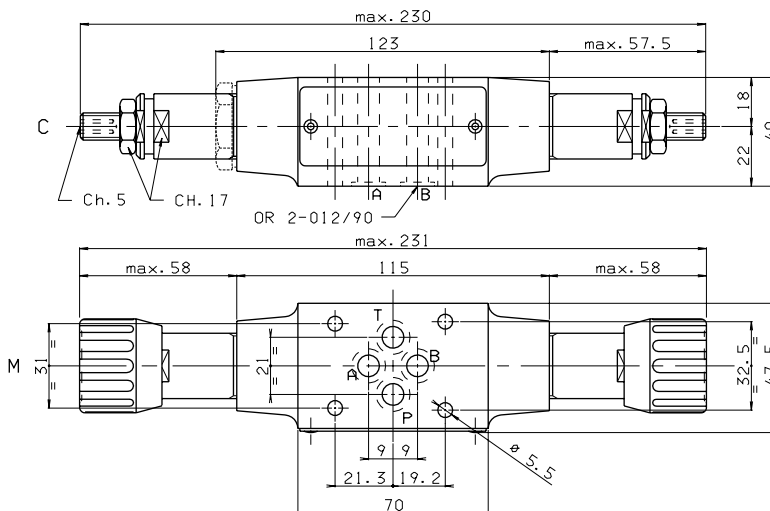

Type of adjustment

- M Plastic knob
- C Grub screw

Support plane specifications

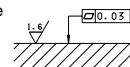

AM.3.VM.P...

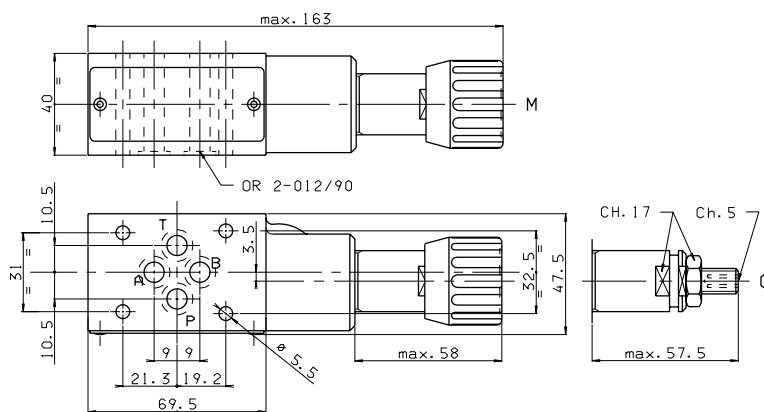

Type of adjustment

- M Plastic knob
- C Grub screw

Support plane specifications

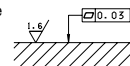

AM.3.VI.AB...

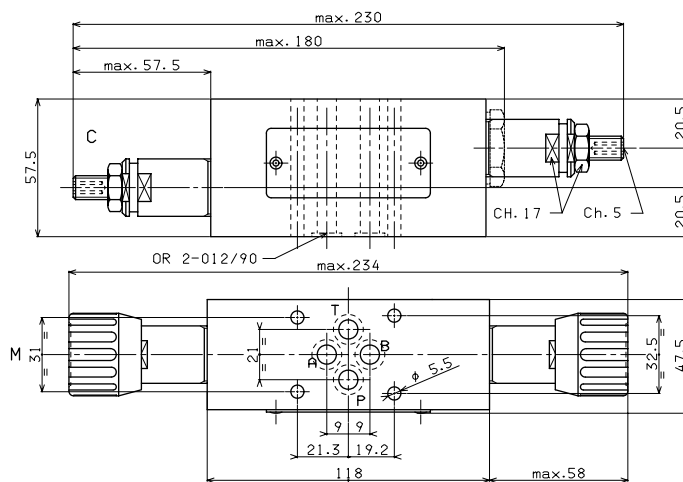

Type of adjustment

- M Plastic knob
- C Grub screw

Support plane specifications

